



Coloris disponibles



Coloris des pieds disponibles



galvanisé



RAL 7016

Gamme Color



Table de pique-nique FP180 réf. FP180.TPN

- Largeur 135 cm, hauteur 73 cm
- Longueur 180 cm
- Plateau composé de lattes de section 3,2x15 cm
- Assises composées de lattes de section 4x12 cm
- Pieds en finition galvanisée ou laquée RAL 7016
- Fixation par 8 goujons d'ancrage réf. GOUJ100 en option
- Poids : 88 kg
- Livrée en kit

Lattes renforcées



Version avec pieds galvanisés

fixation au sol obligatoire pour assurer une bonne stabilité

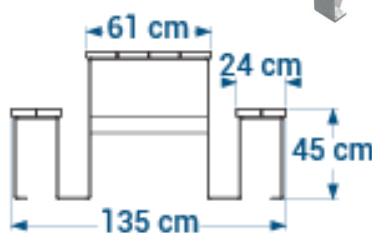
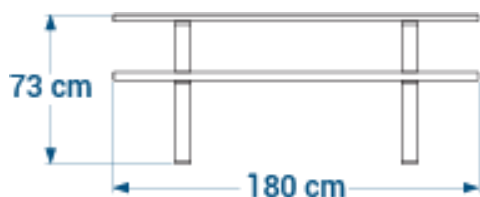

Table de pique-nique FP180 réf. FP180.TPN.G.jrb

- Également disponible en coloris bleu, jaune, rouge ou multicolores
- Plateau composé de lattes de section 4x15 cm





Coloris disponibles



Coloris des pieds disponibles



galvanisé



RAL 7016

Gamme Color

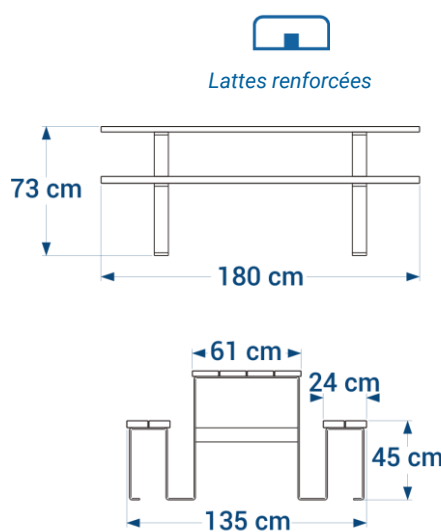

Table de pique-nique FP180 réf. FP180.TPN

- Largeur 135 cm, hauteur 73 cm
- Longueur 180 cm
- Plateau composé de lattes de section 3,2x15 cm
- Assises composées de lattes de section 4x12 cm
- Pieds en finition galvanisée ou laquée RAL 7016
- Fixation par 8 goujons d'ancrage réf. GOUJ100 en option
- Poids : 88 kg
- Livrée en kit

fixation au sol obligatoire pour assurer une bonne stabilité



Table de pique-nique FP180 PMR réf. FP180.TPN.PMR

- Largeur 135 cm, hauteur 73 cm
- Longueur plateau 210 cm, longueur d'assise 180 cm
- Plateau composé de lattes de section 3,2x15 cm
- Assises composées de lattes de section 4x12 cm
- Pieds en finition galvanisée ou laquée RAL 7016
- Fixation par 8 goujons d'ancrage réf. GOUJ100 en option
- Poids : 93,5 kg
- Livrée en kit

fixation au sol obligatoire pour assurer une bonne stabilité

