



Corbeille CANOPÉE ref. 03.11

- Dimensions L.50 x P.50 x H.90 cm
- Ossature en plastique recyclé
- Porte frontale avec verrouillage à clé
- Porte et panneaux d'épaisseur 2,8 cm
- Contenance : porte-sac 130 L
- Trappe en aluminium
- Fixation par 2 équerres et goujons d'ancrage ref. EQ/GOUJ en option
- Poids : 60 kg

Corbeille CANOPÉE ref. 03.11.jrb

- Également disponible en coloris bleu, jaune, rouge ou multicolores

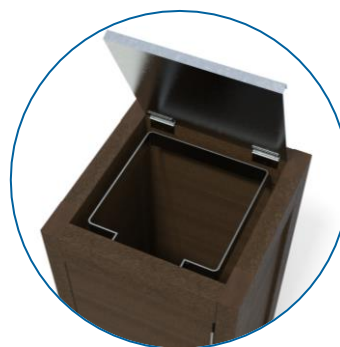

Porte-sac carré 130L



Version tri ref. 03.11.TRI

- 2 portes-sacs 60 L
- Signalétique incluse
- Poids : 61 kg

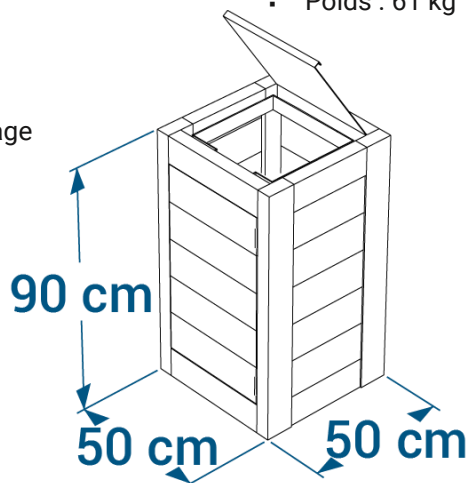

Coloris disponibles



Gamme Color





Coloris disponibles



Gamme Color



Porte-sac carré 130L



Version tri réf. 03.11.VP.PLEX.TRI

- 2 portes-sacs 60 L
- Signalétique incluse
- Poids total : 61 kg

Corbeille CANOPÉE Vigipirate plexi

réf. 03.11.VP.PLEX

- Dimensions L.50 x P.50 x H.90 cm
- Ossature en plastique recyclé
- Porte frontale avec verrouillage à clé
- Porte et panneau arrière d'épaisseur 2,8 cm
- Côtés en plexiglas d'épaisseur 6 mm
- Contenance : porte-sac 130 L
- Trappe en aluminium
- Fixation par 2 équerres et goujons d'ancrage réf. EQ/GOUJ en option
- Poids : 57 kg

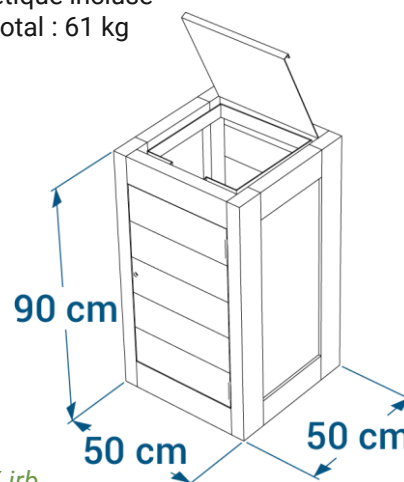

Corbeille CANOPÉE Vigipirate plexi réf. 03.11.VP.PLEX.jrb

- Également disponible en coloris bleu, jaune, rouge ou multicolores

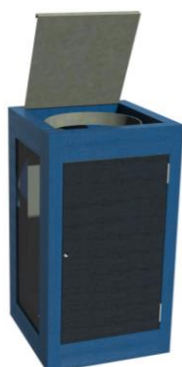



Porte-sac carré 130L

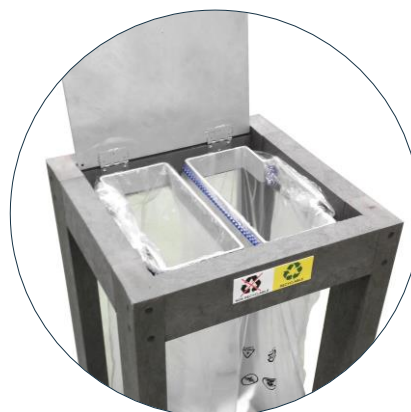

Version tri réf. 03.11.VP.TRI

- 2 portes-sacs 60 L
- Signalétique incluse
- Poids : 32 kg

Corbeille CANOPÉE Vigipirate

réf. 03.11.VP

- Dimensions L.50 x P.50 x H.90 cm
- Ossature en plastique recyclé
- Contenance : porte-sac 130 L
- Trappe en aluminium
- Fixation par 2 équerres et goujons d'ancrage réf. EQ/GOUJ en option
- Poids : 30 kg

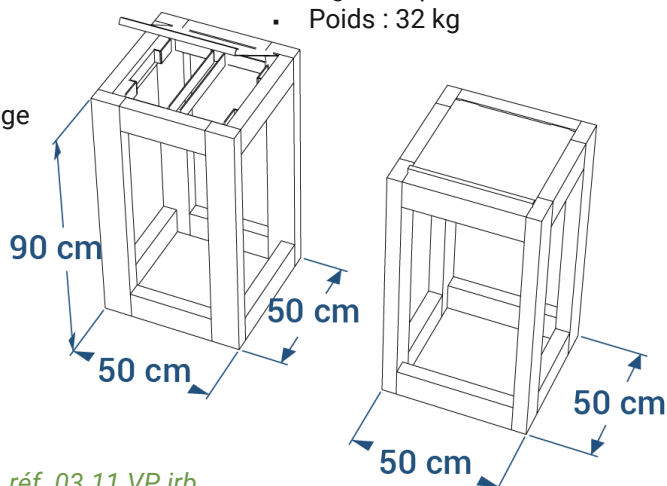

Corbeille CANOPÉE Vigipirate réf. 03.11.VP.jrb

- Également disponible en coloris bleu, jaune, rouge ou multicolores





Coloris disponibles



Gamme Color



Corbeille CANOPÉE Vigipirate plexi avec protège-pluie

réf. 03.15.VP.PLEX

- Dimensions L.50 x P.50 x H.108,5 cm
- Ossature en plastique recyclé
- Porte frontale avec verrouillage à clé
- Porte et panneau arrière d'épaisseur 2,8 cm
- Côtés en plexiglas d'épaisseur 6 mm
- Contenance : porte-sac 130 L
- Fixation par 2 équerres et goujons d'ancrage réf. EQ/GOUJ en option
- Poids : 57 kg

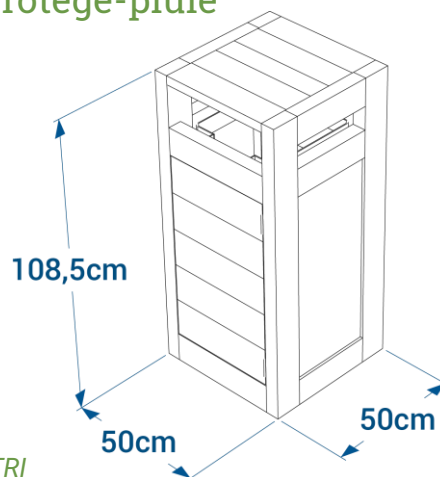

Version tri réf. 03.15.VP.PLEX.TRI

- 2 portes-sacs 60 L
- Signalétique incluse
- Poids total : 58 kg

Corbeille CANOPÉE Vigipirate plexi avec protège-pluie

réf. 03.15.VP.PLEX.jrb

- Également disponible en coloris bleu, jaune, rouge ou multicolores

